

ADJUSTABLE LEGS

ALFM5

Adjustable Leg - Weld-on

Length: 500mm. Front- No wheel

Type: Metric thread,
Hex-head handle fitment.

Unit Weight: 3.6kg

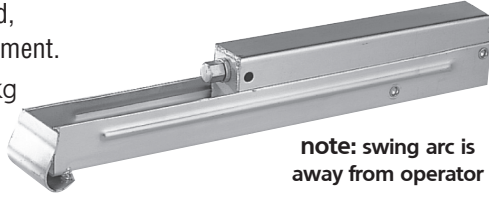

note: swing arc is away from operator

ALFP5

Adjustable Leg - Weld-on

Length: 500mm. Front- No wheel

Type: Power thread,
slotted type handle fitment.

Unit Weight: 3.4kg



note: swing arc is towards operator

ALRM5

Adjustable Leg - Weld-on

Length: 500mm. Rear- With wheel

Type: Metric thread,
Hex-head handle fitment.

Unit Weight: 3.7kg

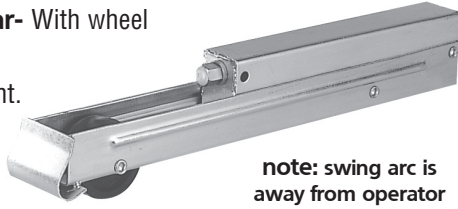

note: swing arc is away from operator

ALRP5

Adjustable Leg - Weld-on

Length: 500mm. Rear- With wheel

Type: Power thread,
slotted type handle fitment.

Unit Weight: 3.5kg



note: swing arc is towards operator

ALFM6

Adjustable Leg - Weld-on

Length: 600mm. Front- No wheel

Type: Metric thread,
Hex-head handle fitment.

Unit Weight: 3.8kg

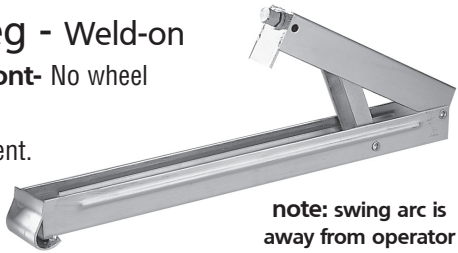

note: swing arc is away from operator

ALFP6

Adjustable Leg - Weld-on

Length: 600mm. Front- No wheel

Type: Power thread,
slotted type handle fitment.

Unit Weight: 3.6kg



note: swing arc is towards operator

ALRM6

Adjustable Leg - Weld-on

Length: 600mm. Rear- With wheel

Type: Metric thread,
Hex-head handle fitment.

Unit Weight: 4.0kg

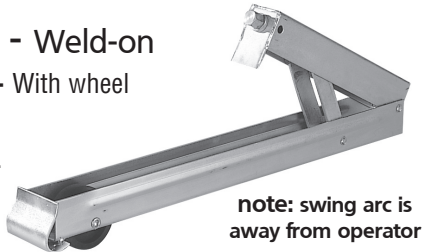

note: swing arc is away from operator

ALRP6

Adjustable Leg - Weld-on

Length: 600mm. Rear- With wheel

Type: Power thread,
slotted type handle fitment.

Unit Weight: 3.8kg

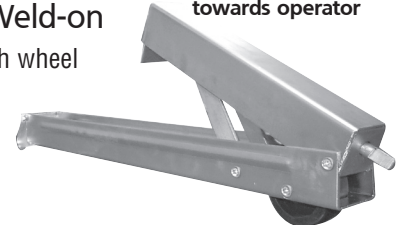

note: swing arc is towards operator

ALFM5BOGA

Adjustable Leg Galv - Zinc Weld-on
brackets fitted - Leg removable

Length: 500mm. Front- No wheel

Type: Metric thread,
Hex-head handle fitment.

Unit Weight: 4.4kg

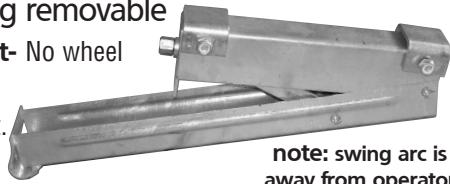

note: swing arc is away from operator

ALFM6BOGA

Adjustable Leg Galv - Zinc Weld-on
brackets fitted - Leg removable

Length: 600mm. Front- No wheel

Type: Metric thread, Hex-head
handle fitment.

Unit Weight: 4.6kg

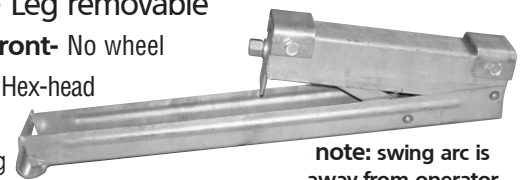

note: swing arc is away from operator

M series handles

hex-head type

LH2M



Length: 700mm.

Weight: 840grams

LH3M



Length: 900mm.

Weight: 1kg

LH2MD



Length: 590mm.

Weight: 600grams

P series handles

slotted type

LH1P



Length: 550mm.

Weight: 560grams

LH2P



Length: 700mm.

Weight: 680grams

LH3P



Length: 900mm.

Weight: 840grams

LH2PD



Length: 570mm.

Weight: 500grams

ALQR1

Adjustable Leg - Weld-on
Unit Weight: 4.7kg

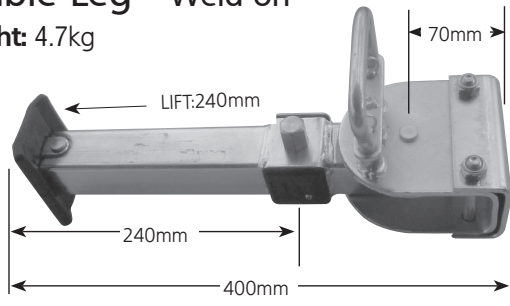

ALQR2

Adjustable Leg - Weld-on
Unit Weight: 5.1kg

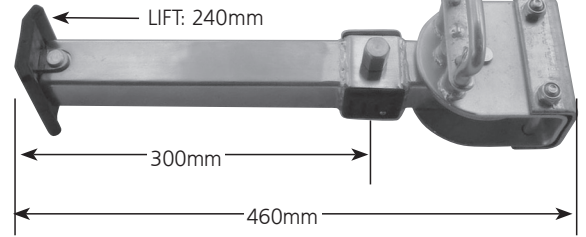

ALQR1-AF

As above - with new large aluminium foot option
Unit Weight: 4.7kg

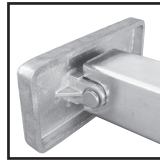

ALQR2-AF

As above - with new large aluminium foot option
Unit Weight: 5.1kg

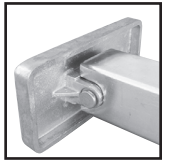

ALQR3

Adjustable Leg - Weld-on
Unit Weight: 5.7kg

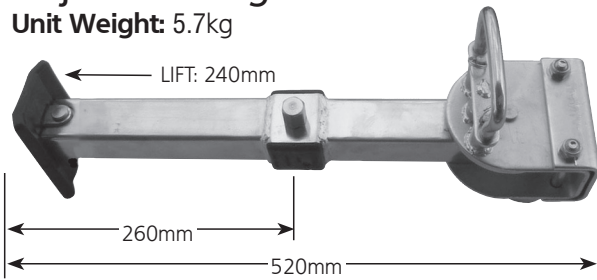

ALQR3-AF

As above - with new large aluminium foot option
Unit Weight: 5.7kg

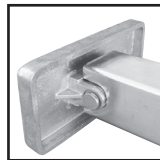

ALQR4LP

Adjustable Leg - Weld-on
Unit Weight: 6.2kg

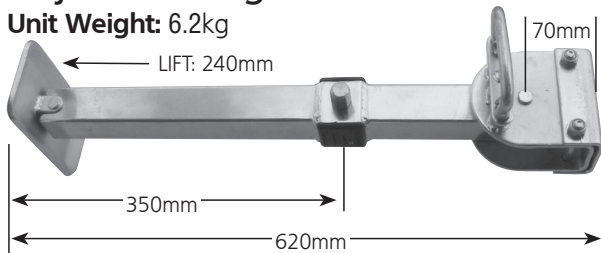

ALQR4-AF

As above - with new large aluminium foot option
Unit Weight: 6.2kg

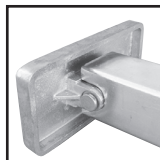

Quick Action Stabilising Legs: Pull handle to swing leg into lowest lock position (variable). Take up support weight using hex-head handle.



Note: Support capacity varies depending on angle of leg and surface grip of foot. Generally, a more vertical position will give greater load capacity, but will reduce stability.

Handle to suit ALQR hex-head type

LH1M



Length: 600mm.

Weight: 740grams